

ELECTRICAL AND THERMOELECTRICAL PROPERTIES OF PURE AND  
SUBSTITUTED COPPER FERRITES

MOHAMED A. AHMED, MOHAMED A. EL-HITI and MOHAMED E. EL-SHABASY\*

*Physics Department, Faculty of Science, Tanta University, Tanta, Egypt*

\* *Physics Department, Faculty of Science, El-Minia University, El-Minia, Egypt*

Received 21 January 1994

Revised manuscript received 22 March 1994

UDC 538.93

PACS 72.15.Eb, 72.15.Jfx

Samples of the  $\text{CuFe}_{2-x}\text{Al}_x\text{O}_4$  system with  $x = 0, 0.2, 0.4$  and  $0.6$  were prepared. The single phase spinel structure was verified by X-ray diffraction method. The thermoelectric power ( $\alpha$ ) and dc electrical resistivity ( $\rho$ ) were studied as a function of temperature and composition. The results show that the resistivity increases and the transition temperature decreases with increasing the aluminium substitution. The activation energy in ferrimagnetic region is lower than that in paramagnetic region. The drift mobility of carriers increases exponentially with temperature as expected for ferrites.

## 1. Introduction

Ferrites have low conductivity. This is one of the reasons for their many applications [1,2]. The activation energy for electrical conductivity was found to be smaller in ferrimagnetic region than that in paramagnetic region [3,4,5]. The electronic conduction mechanism of ferrites containing  $\text{Fe}^{2+}$  ions was explained by the

hopping motion of electrons between  $\text{Fe}^{2+}$  and  $\text{Fe}^{3+}$  ions on the octahedral sites of the spinel ferrites [6].

The aim of the present work was to study the dc resistivity and the thermoelectric power for varied substitution of non magnetic aluminium atoms in place of magnetic iron atoms in copper ferrites.

## 2. Experimental

Samples of  $\text{CuFe}_{2-x}\text{Al}_x\text{O}_4$  system with  $x = 0, 0.2, 0.4$  and  $0.6$  were prepared by the usual ceramic technique. Samples were pressed in the form of tablets at a pressure of  $5 \text{ tons/cm}^2$  and sintered at  $1300^\circ\text{C}$  for 6 hours.

For electrical resistivity measurements, the samples were polished and held between copper electrodes with silver paste. They were inserted with the holder into a cylindrical chamber under vacuum in order to get stable measurements. An electric heater pressed against one end of the sample provided the necessary temperature gradient. One end of the sample holder protruded from the furnace so that the temperature gradient along the sample holder provided a temperature difference between the two faces of the tablet. The thermovoltage ( $\Delta V$ ) divided by the temperature gradient ( $\Delta T$ ) gives the thermoelectric power ( $\alpha$ ), where

$$\alpha = \frac{\Delta V}{\Delta T}.$$

No contact material between the sample surfaces and electrodes was introduced. The temperature gradient for all samples was nearly constant ( $60^\circ\text{C/cm}$ ) in the whole temperature region. The sign of  $\alpha$  was taken with respect of the cold surface of the sample. The temperature of the two surfaces of the sample was measured by calibrated Ni-Cr-Ni thermocouples [7].

The details of the apparatus used for the thermoelectric power measurements are shown in Fig. 1. It consisted of a sample holder (1) held by three iron rods (2). A stainless steel sample holder (3) was fixed in the central axis of the tubular stainless steel furnace (4) and (5). The two heaters and the stainless steel bar were fixed to the holder base. Central steel bar, copper leads thermocouple wires and heaters connections were insulated from the holder base plate by ceramic disc (6). All the wires pass through ceramic tubes and through teflon tubes (7) to external copper leads (8). The sample S was tightly pressed between two copper electrodes by means of a load (9) screwed to the rods. The system was surrounded by a metal jacket (10) which rested on an annular vacuum rubber ring (11). Cooling copper coil (12) was sealed on the metal jacket.

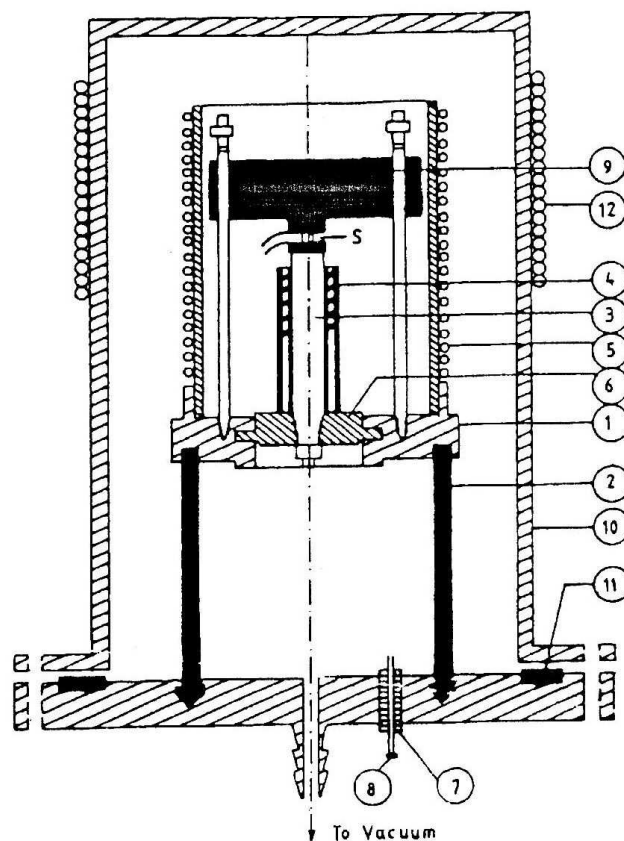

Fig. 1. Cross-section of the apparatus used for thermoelectric power measurements. (1) Sample holder. (2) Three ion rods. (3) Stainless steel sample holder. (4), (5) Central axis of the tubular stainless steel furnace. (6) Ceramic disc. (7) Teflon tubes. (8) Copper leads. (9) Load. (10) Metal jacket. (11) Vacuum rubber ring. (12) Cooling copper coil.

### 3. Results and discussion

#### 3.1. Temperature dependence of resistivity and thermopower

The electrical resistivity ( $\rho$ ) and thermoelectric power ( $\alpha$ ) have been measured as a function of temperature. A typical graph of  $\ln \rho$  and of thermoelectric power  $\alpha$  versus  $1/T$  for composition  $x = 0$  and  $x = 0.2$  is shown in Fig. 2, and for composition  $x = 0.4$  and  $x = 0.6$  in Fig. 3.

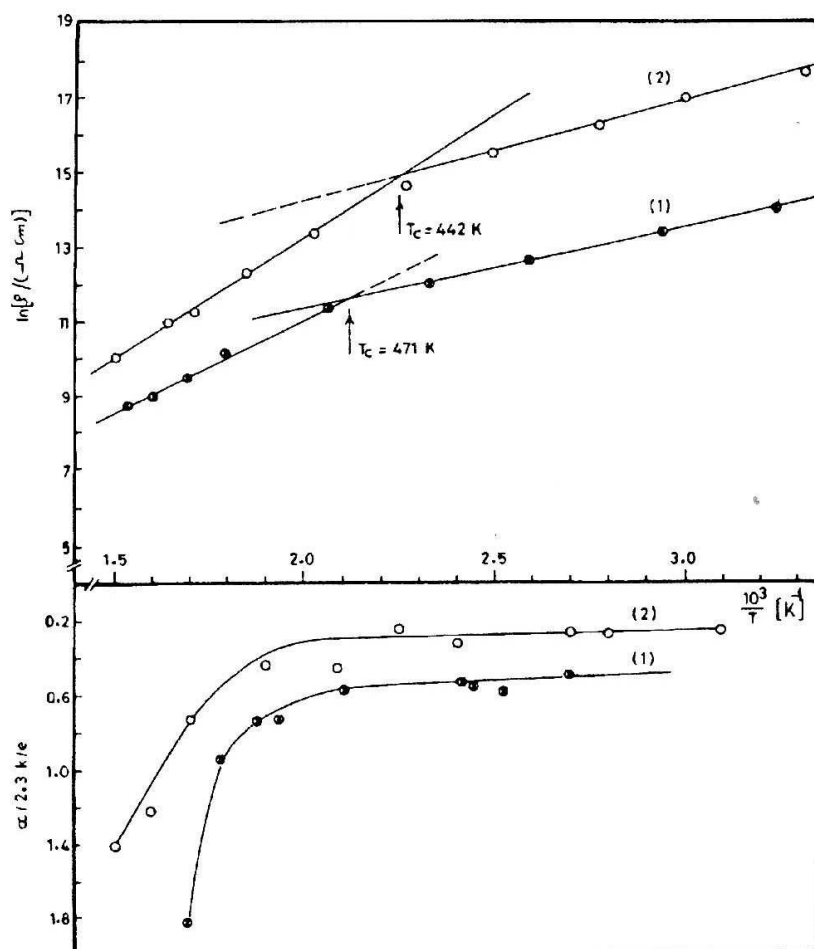

Fig. 2. Temperature dependence of resistivity  $\rho$  and thermopower  $\alpha$  for samples  $x = 0$  (1) and  $x = 0.2$  (2).

The curves show a characteristic break in the slope at the transition temperature  $T_C$  (Curie temperature). From Figs. 2 and 3 one can observe that the resistivity decreases with increasing temperature, showing semiconducting behaviour according to the relation

$$\rho = \rho_{\infty} \exp(E/kT),$$

where  $E$  is the activation energy necessary for electron hopping from an ion to the neighbouring one giving rise to the electrical conductivity [8],  $k$  is the Boltzmann constant and  $T$  the absolute temperature. The present results confirm the conclusion of Sinsa [9] and Griffiths et al. [10].

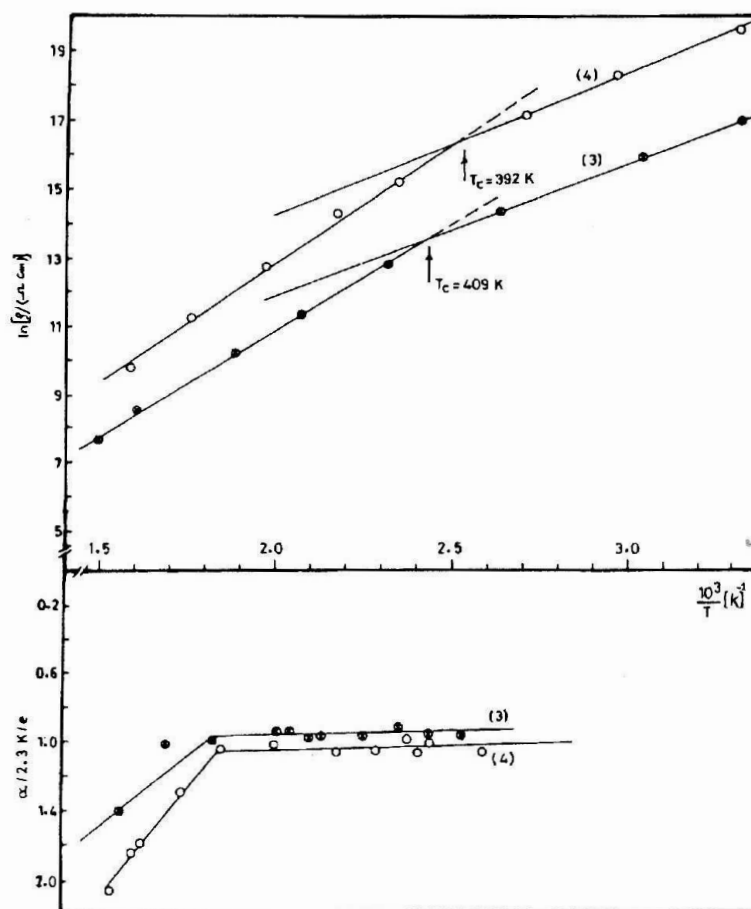

Fig. 3. Temperature dependence of resistivity  $\rho$  and thermopower  $\alpha$  for samples  $x = 0.4$  (3) and  $x = 0.6$  (4).

The two segments of each resistivity curve show an appreciable increase in activation energy after passing the Curie temperature  $T_C$ : from 0.17 to 0.43 eV for  $x = 0$ , from 0.23 to 0.55 eV for  $x = 0.2$  (Fig. 2), from 0.33 to 0.52 eV for  $x = 0.4$  and from 0.35 to 0.60 eV for  $x = 0.6$  (Fig. 3).

Thermoelectric power  $\alpha$  is negative, i.e. the majority of carriers are electrons. It has nearly a constant value over a wide range of temperature. Its magnitude increases at higher temperature. That may be due to activated electron hopping [4] from  $\text{Fe}^{2+}$  to  $\text{Fe}^{3+}$  ions. The results indicate that in the range of constant thermoelectric power, the conduction is due to a hopping mechanism. In the range where  $\alpha$  increases with temperature, the conduction is due to hopping and/or conduction mechanism i.e. both  $\mu$  (drift mobility) and  $n$  (carrier concentration) increase with temperature ( $\sigma = ne\mu$ ).

## 3.2. Composition dependence

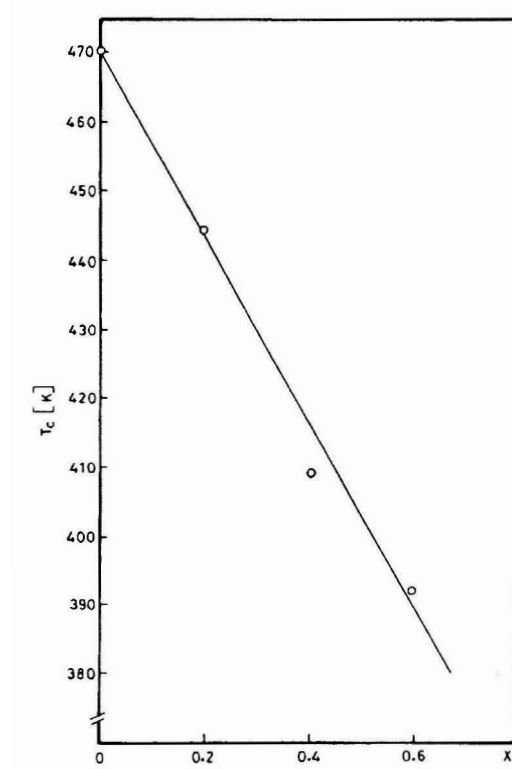

Fig. 4. Variation of transition temperature  $T_C$  versus Al substitution  $x$ .

The transition temperature  $T_C$  is decreasing linearly with increasing aluminium substitution  $x$  of trivalent iron ions as shown in Fig. 4. This result may be due to decrease of magnetic ions ( $\text{Fe}^{3+}$ ) in octahedral sites as  $\text{Al}^{3+}$  (non magnetic ions) replace  $\text{Fe}^{3+}$  in B-sites [11], which affect the magnetic order. The transition temperature  $T_C$  and the activation energies in ferrimagnetic region  $E_F$  (ordered state) and paramagnetic region  $E_p$  (disordered state) are given in Table 1.

TABLE 1.

Comparison between the changes of activation energies  $E_F$  and  $E_p$  and the transition temperature  $T_C$ .

Num. of sampl.	Molecular formula	$T_C$ (K)	$E_F$ (eV)	$E_p$ (eV)	$E = E_p - E_F$ (eV)
1	$\text{CuFe}_2\text{O}_4$	471	0.17	0.44	0.27
2	$\text{CuFe}_{1.8}\text{Al}_{0.2}\text{O}_4$	442	0.23	0.56	0.33
3	$\text{CuFe}_{1.6}\text{Al}_{0.4}\text{O}_4$	409	0.31	0.53	0.20
4	$\text{CuFe}_{1.4}\text{Al}_{0.6}\text{O}_4$	392	0.36	0.60	0.24

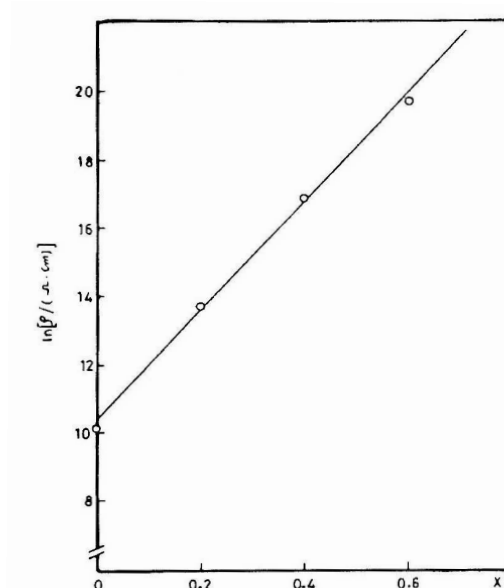

Fig. 5. Variation of dc resistivity ( $\ln \rho$ ) versus Al substitution  $x$ .

Fig. 5. shows the composition dependence of resistivity. It illustrates that the resistivity increases exponentially with the aluminium substitution that could be described by the expression

$$\rho = Ae^x$$

where  $A$  is constant and  $x$  is nonmagnetic substitution.

### 3.3. Temperature dependence of the drift mobility

In the temperature range where the thermopower is independent of temperature (Figs. 2 and 3), the carrier concentration is constant. The decrease of resistivity in the same region indicates that the drift mobility of electrons  $\mu_n$  increases with temperature. In spinel ferrites thermoelectric power  $\alpha$  can be given by [12]

$$\alpha \approx \frac{2.3k}{e} \ln \left( \frac{N}{n} - 1 \right)$$

where  $N$  is the concentration of  $\text{Fe}^{3+}$  ions on octahedral sites ( $N \approx 1.35 \times 10^{22}$  atoms/cm<sup>3</sup>),  $e$  is the elementary charge,  $k$  is the Boltzmann constant and  $n$  is the carrier concentration.

Thus, the carrier concentration  $n$  can be calculated from the result for  $\alpha$ . The drift mobility  $\mu_n$  is then calculated (at different temperatures) by substituting  $n$

and the corresponding value of resistivity  $\rho$  in the following equation:

$$\mu_n = \frac{1}{ne\rho}.$$

The obtained values of  $\ln \mu_n$  versus reciprocal temperature are shown in Fig. 6: It can be seen that the drift mobility increases exponentially with temperature, as expected in the case of ferrites.

The presented results are in good agreement with the previous investigations [5,12,13,14,15] of the other ferrites.

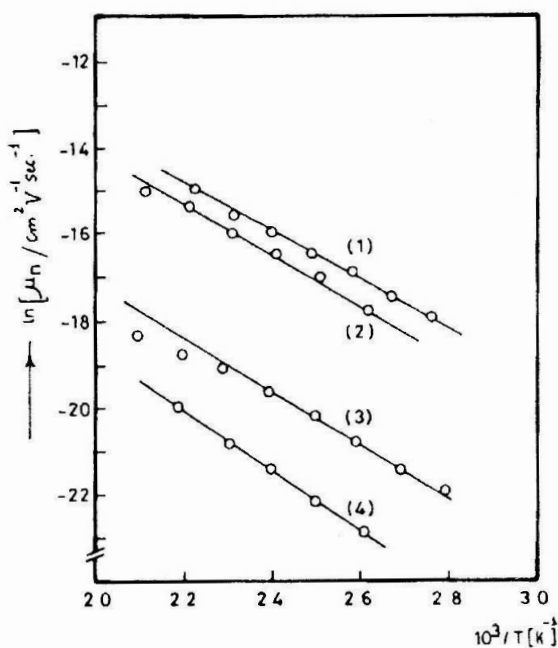

Fig. 6. Variation of the drift mobility ( $\ln \mu_n$ ) versus reciprocal temperature ( $10^3/T$ ):  $x = 0$  (1),  $x = 0.2$  (2),  $x = 0.4$  (3) and  $x = 0.6$  (4).

#### References

- 1) J. Kulikowski and A. Lesniewski, J. Mag. Magn. Mater. **19** (1980) 117;
- 2) H. Igarashi and K. Okazaki, J. Amer. Ceram. Soc. **60** (1977) 51;
- 3) A. A. Ghani and N. Z. Mirijarov, Sov. Phys. Sol. State **13** (1972) 2627;
- 4) M. A. Ahmed, M. K. El-Nimr, A. Tawfik and A. M. Abou El-Ata, J. Mat. Sci. Letters **7** (1988) 639;
- 5) M. A. Ahmed, M. K. El-Nimr, A. Tawfik and A. M. El-Hasab, Phys. Stat. Sol. (a) **123** (1991) 501;



- 6) I. G. Austin and N. F. Moh, *Adv. Phys.* **18** (1969) 41;
- 7) A. A. Ghani and M. A. Ahmed, *Proc. Math. & Phys. Soc. (Egypt)* **12** (1976) 93;
- 8) L. G. Van Uitert, *J. Chem. Phys.* **23** (1955) 1883;
- 9) Z. Simsa, *Chzech. J. Phys.* **B 16** (1966) 919;
- 10) B. G. Griffiths, D. Elwell and R. Parker, *Phil. Mag.* **22** (1970) 163;
- 11) E. A. Zhurakavaskii, T. D. Bakruma, V. Ya Garmash and G. S. Podvalnykh, *Sov. Phys., Powder and Metall. Ceram.* **23** (1984) 235;
- 12) M. A. Ahmed, *Phys. Stat. Sol. (a)* **111** (1989) 567;
- 13) F. J. Morin, *Phys. Rev.* **93** (1954) 1195;
- 14) F. J. Morin, *Phys. Rev.* **93** (1954) 1199;
- 15) A. A. Samokhvalov and A. G. Rustamov, *Sov. Phys. Sol. State* **7** (1965) 961.

ELEKTRIČNA I TERMOELEKTRIČNA SVOJSTVA ČISTOG I  
SUPSTITUIRANIH BAKRENIH FERITA

MOHAMED A. AHMED, MOHAMED A. EL-HITI i MOHAMED E. EL-SHABASY

*Physics Department, Faculty of Science, Tanta University, Tanta, Egypt*

UDK 538.93

PACS 72.15.Eb, 72.15.Jfx

Priređeni su uzorci sistema  $\text{CuFe}_{2-x}\text{Al}_x\text{O}_4$  sa  $x = 0, 0,2, 0,4$  i  $0,6$ . Proučavana je termoelektrična sila i dc električna otpornost u ovisnosti o temperaturi i sastavu. Rezultati mjerenja pokazuju da se otpornost povećava a temperatura prijelaza smanjuje sa povećanjem koncentracije aluminija. Aktivacijska energija veća je u feromagnetskoj nego u paramagnetskoj fazi. U skladu s očekivanjem, ustanovljeno je da se mobilnost nosilaca naboja u feritima eksponencijalno povećava s temperaturom.